



KU LEUVEN
TECHNOLOGIECAMPUS GENT

HEIn4.0

PROFenergy:
Smart energy-savings with PROFINET



15/12/2020

Philippe Saey
Mathieu Troch
Dimitri De Schuyter
Frederic Depuydt
Arne Verhoeven

philippe.saey@kuleuven.be

1

Outline

- PROFenergy
 - Energy savings in manufacturing industries
 - What is PROFenergy?
 - Energy saving potential (PI – Daimler)
- Large test set-up - Measurements
- Calculation tool – Some results
- Q & A



The European Commission's support for the production of this publication does not constitute an endorsement of the contents, which reflect the views only of the authors, and the Commission cannot be held responsible for any use which may be made of the information contained therein.

Boosting the role of HEIs in the industrial transformation towards the Industry 4.0 paradigm in Georgia and Ukraine
609939-EPP-1-2019-1-BE-EPPKA2-CBHE-JP

HEIn4.0  Co-funded by the Erasmus+ Programme of the European Union **KU LEUVEN**
TECHNOLOGIECAMPUS GENT

2

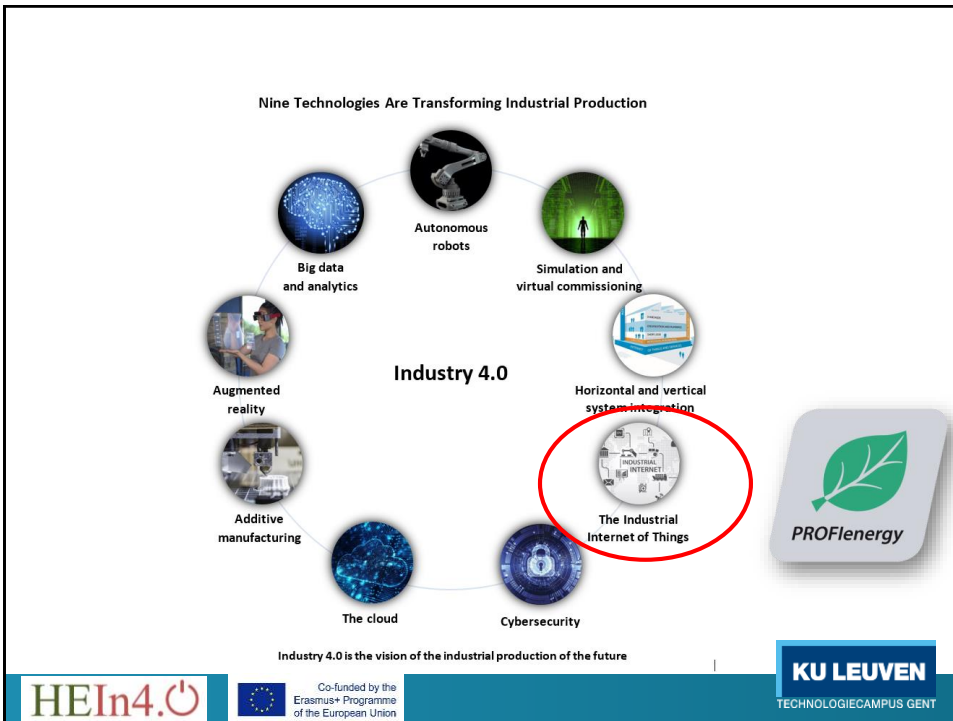

3

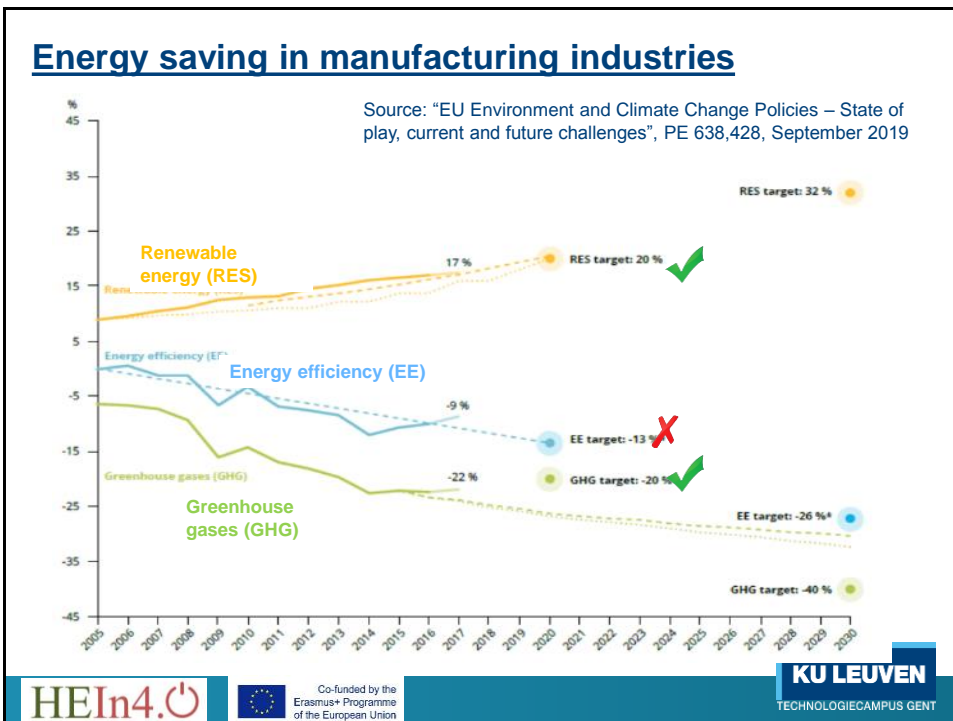

4

Energy saving in manufacturing industries

Final energy consumption of electricity

Million tonnes of oil equivalent

“Who is using how much energy?”

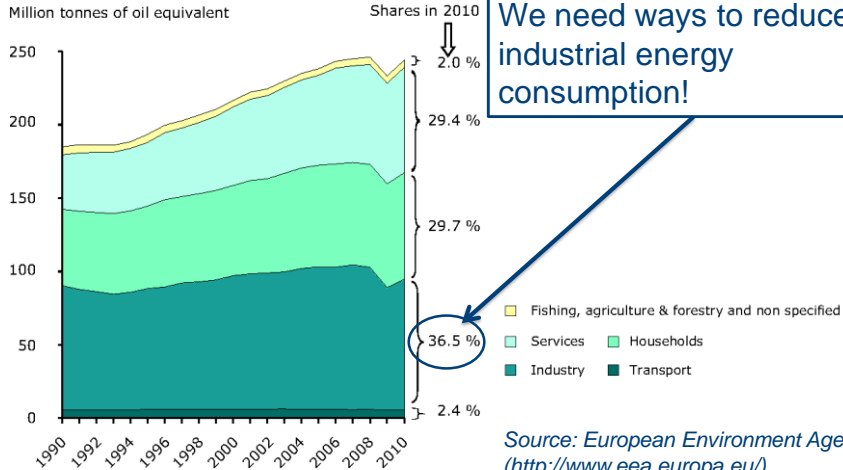

We need ways to reduce industrial energy consumption!

HEIn4.0

Co-funded by the Erasmus+ Programme of the European Union

KU LEUVEN

TECHNOLOGIECAMPUS GENT

5

Energy saving in manufacturing industries

How to reduce energy consumption:

1. Reduce consumption during production

- ⇒ Often not possible, unless you (totally) renew the production process
- ⇒ Expensive (new hardware, develop new processes, etc.)

Consumption

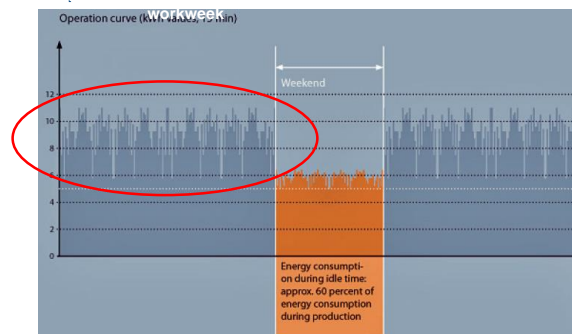

HEIn4.0

Co-funded by the Erasmus+ Programme of the European Union

KU LEUVEN

TECHNOLOGIECAMPUS GENT

6

Energy saving in manufacturing industries

How to reduce energy consumption:

2. **Reduce consumption in idle-time**: short and longer pauses, weekend

=> Problem: Shutdown and start-up of (large scale) factory automation is complicated

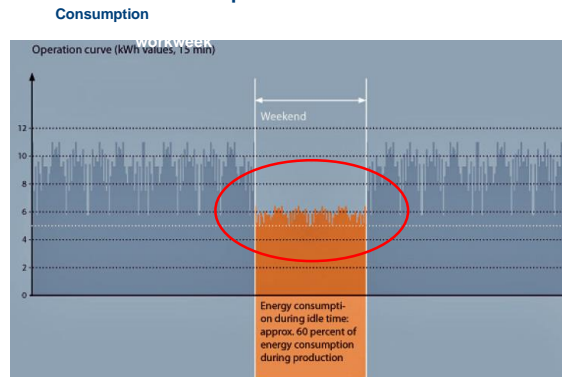

E.g. in car manufacturing industries, about 60% of the energy used during production is still "consumed" during idle time

HEIn4.0

Co-funded by the Erasmus+ Programme of the European Union

KU LEUVEN
TECHNOLOGIECAMPUS GENT

7

Energy saving in manufacturing industries

2. **Reduce consumption in idle-time**: short and longer pauses, weekend. **How?**

Traditional way: switches, with an additional controller

- Complex routines (start-up, interlocks, etc.) are possible, but require additional programming
 - expensive
- Additional wiring & hardware/controller
 - expensive
- A device can still only be switched completely off/on

→ **NOT OFTEN IMPLEMENTED**

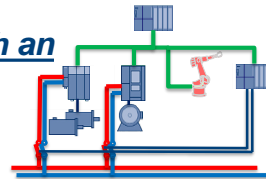

HEIn4.0

Co-funded by the Erasmus+ Programme of the European Union

KU LEUVEN
TECHNOLOGIECAMPUS GENT

8

Energy saving in manufacturing industries

2. Reduce consumption in idle-time: short and longer pauses, weekend. **How?**

We need something else ...

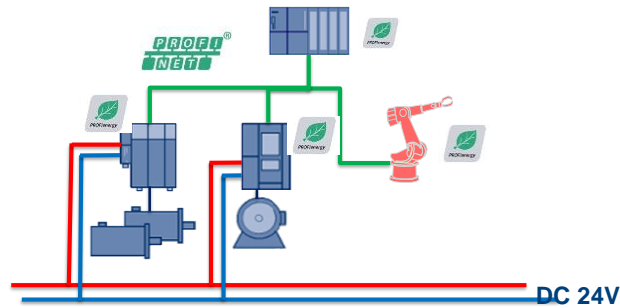

Source: Y. Vandorpe, "PROFINET & Energy savings," Siemens NV, Edegem, 2012

HEIn4.0

Co-funded by the
Erasmus+ Programme
of the European Union

KU LEUVEN
TECHNOLOGIECAMPUS GENT

9

... We need something like your television at home:
powered on, stand by (sleep), no extra components
needed ...



... Or something like your portable PC, Wake-up on Lan ...

HEIn4.0

Co-funded by the
Erasmus+ Programme
of the European Union

KU LEUVEN
TECHNOLOGIECAMPUS GENT

10

Outline

- PROFlenergy
 - Energy savings in manufacturing industries
 - **What is PROFlenergy?**
 - Energy saving potential (PI – Daimler)
- Large test set-up - Measurements
- Calculation tool – Some results
- Q & A



11

What is PROFlenergy?

→ A profile based on **PROFINET** (leading ethernet based industrial network)

→ First requested by **German automobile manufacturing industry (AIDA)**

- → a PI working group set up in 2009



They wanted a standardized, multivendor and “modular” method to save energy during idle time, without introducing a lot of extra hardware.

12

What is PROfEnergy?

End result should be, for both short and long pauses in production, with not much additional hardware and software:

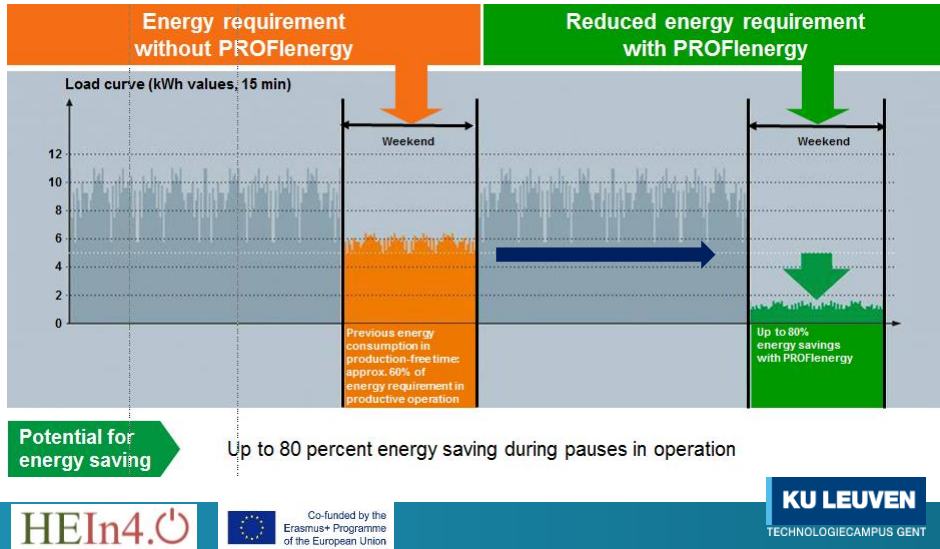

13

What is PROfEnergy?

Typical Use Cases:

- Energy Saving during short pauses (~minutes)
- Energy Saving during longer pauses (~hours/days)
- Energy Saving during an unplanned pause (time?)
- Measuring and visualization of the load/flow of energy



Siemens, "Application Guideline for Implementing Switch-off Concepts with PROfEnergy"

14

What is PROFlenergy?

Energy saving during pauses:

- A trigger starts the pause (pre-defined, uniform, cross-vendor interface based on acyclic communication in a PROFINET industrial network)
- Turning off is in the device itself, no additional external switch necessary
- Devices will be put into stand-by or will be switched off if possible
 - Different (new) levels of stand-by /energy usage
 - Some devices can't be switched off (safety, too long startup/initialization times,...)
- Coordinated starting and stopping

What is PROFlenergy? State model of a PE device

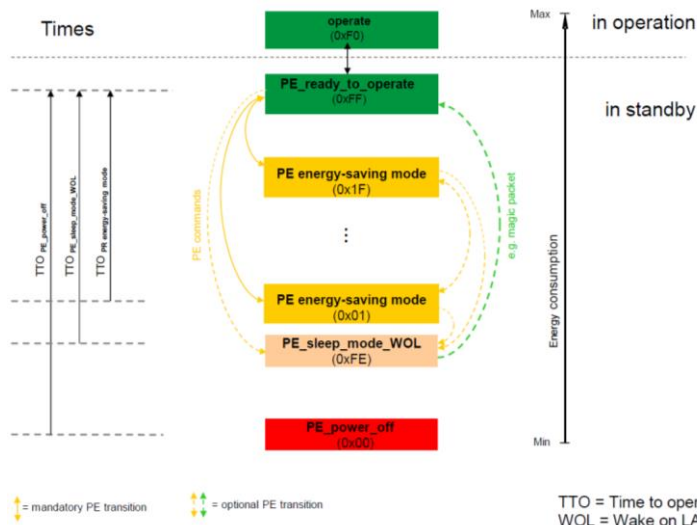

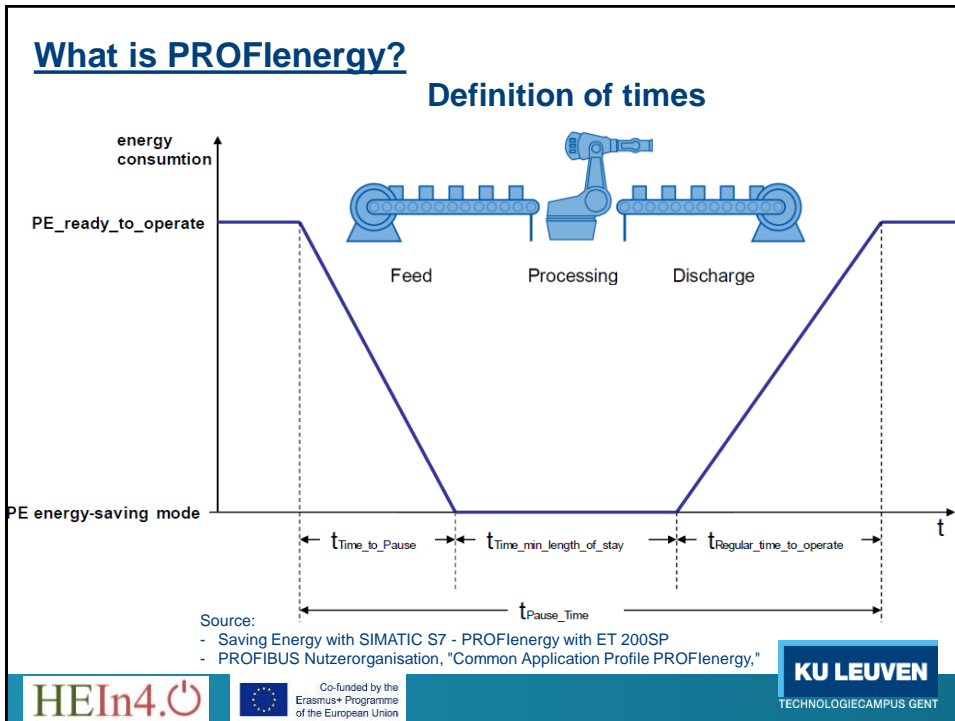

17

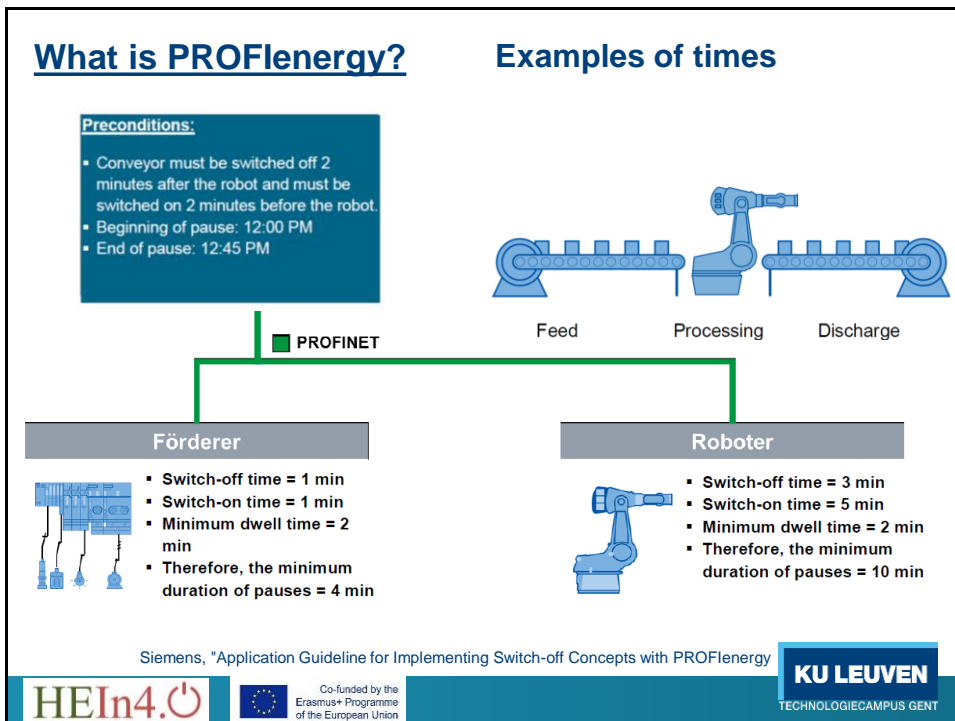

18

What is PROFlenergy? Example of PE operation

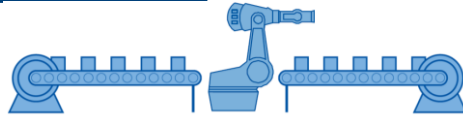

PROFlenergy in practice: example scenarios for a coordinated switch-on/off of a conveyor

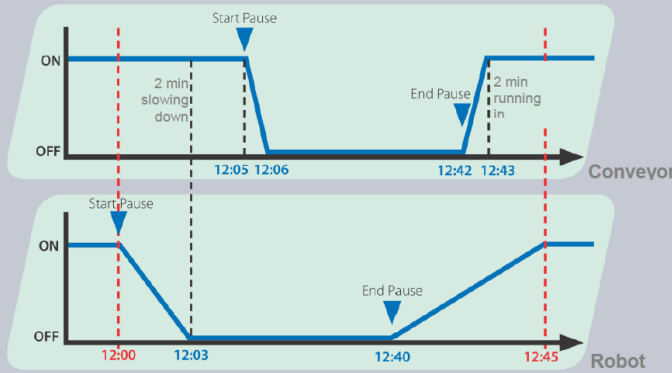

Siemens, "Application Guideline for Implementing Switch-off Concepts with PROFlenergy"



Co-funded by the Erasmus+ Programme of the European Union

KU LEUVEN

TECHNOLOGIECAMPUS GENT

19

What is PROFlenergy? Energy saving during pauses;

TTO = time to operate \rightarrow RTTO = Regular time to operate
 \rightarrow CTTO = Current time to operate

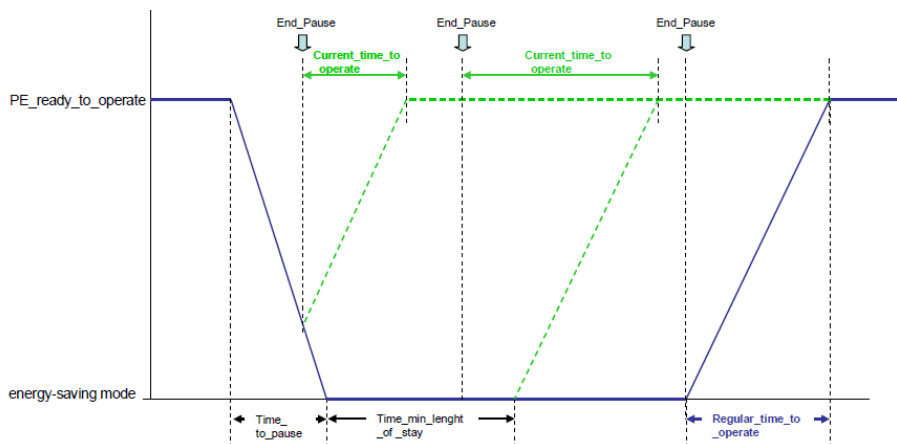

Co-funded by the Erasmus+ Programme of the European Union

KU LEUVEN

TECHNOLOGIECAMPUS GENT

20

How do PROFlenergy commands look like in the network?

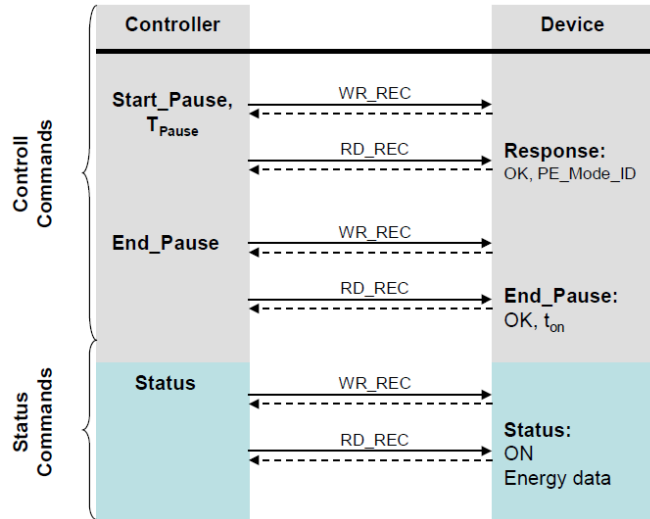

Source: PROFIBUS Nutzerorganisation, "Common Application Profile PROFlenergy,"



21

How do PROFlenergy commands look like in the network?

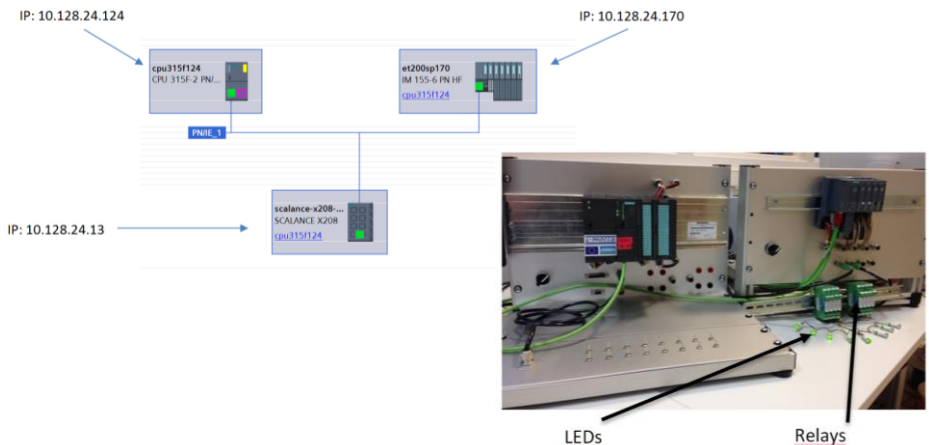

22

How do PROFlenergy commands look like in the network?

No.	Time	Source	Destination	Protocol	Length	Info
38777	19.097263000	10.128.24.124	10.128.24.170	PNIO-CM	220	write request, IOWriteReqHeader, Api:0x0, Slot:0x0/0x1, Index:(0x80a0), 14 bytes
38786	19.101262000	10.128.24.170	10.128.24.124	PNIO-CM	206	write response, OK, IOWriteResHeader, Api:0x0, Slot:0x0/0x1, Index:(0x80a0), OK
38801	19.108263000	10.128.24.124	10.128.24.170	PNIO-CM	206	read request, IOReadReqHeader, Api:0x0, Slot:0x0/0x1, Index:(0x80a0), 14 bytes
38804	19.109259000	10.128.24.170	10.128.24.124	PNIO-CM	218	read response, OK, IOReadResHeader, Api:0x0, Slot:0x0/0x1, Index:(0x80a0), 12 bytes
59014	29.095470000	10.128.24.124	10.128.24.170	PNIO-CM	216	write request, IOWriteReqHeader, Api:0x0, Slot:0x0/0x1, Index:(0x80a0), 10 bytes
59017	29.096450000	10.128.24.170	10.128.24.124	PNIO-CM	206	write response, OK, IOWriteResHeader, Api:0x0, Slot:0x0/0x1, Index:(0x80a0), OK
59032	29.102592000	10.128.24.124	10.128.24.170	PNIO-CM	206	read request, IOReadReqHeader, Api:0x0, Slot:0x0/0x1, Index:(0x80a0), 14 bytes
59033	29.103444000	10.128.24.170	10.128.24.124	PNIO-CM	220	read response, OK, IOReadResHeader, Api:0x0, Slot:0x0/0x1, Index:(0x80a0), 14 bytes

```

#
# Frame 38777: 220 bytes on wire (1760 bits), 220 bytes captured (1760 bits) on Interface 0
# Ethernet II, Src: Siemens:Fa:el:14 (00:0e:8c:fa:el:14), Dst: Siemens_eb:69:9e (00:1b:1b:6b:69:9e)
# Internet Protocol Version 4, Src: 10.128.24.124 (10.128.24.124), Dst: 10.128.24.170 (10.128.24.170)
# User Datagram Protocol, Src Port: 49157 (49157), Dst Port: 49155 (49155)
# Distributed Computing Environment / Remote Procedure Call (DCE/RPC) Request, Seq: 42, Serial: 0, Frag: 0, FragLen: 98, [Resp: #38786]
# PROFINET_io, write
    
```

```

0000 00 1b 1b 6b 69 9e 00 0e 8c fa e1 14 08 00 45 00  ...kI.....E.
0010 00 ce 70 11 00 09 1e 11 e5 e8 0a 80 18 7c 0a 80  ..p.....I..
0020 18 aa c0 05 c0 03 00 ba 65 2b 04 00 20 00 10 00  .....+.....
0030 00 00 00 00 a0 de 97 6c d1 11 82 71 00 01 02 13  .....,.....
0040 00 2a 01 00 a0 de 97 6c d1 11 82 71 00 a0 24 42  .....,.....
0050 ff 7d 11 00 00 00 00 00 10 10 83 43 00 0e 8c fa  .....,.....
0060 e1 14 6b 01 00 00 01 00 00 00 2a 00 00 00 03 00  ..k.....
0070 ff ff ff ff 62 00 00 00 00 00 4e 00 00 00 4e 00  ...B.....N..N.
0080 00 00 4e 00 00 00 00 00 00 00 4e 00 00 00 08  ..N.....N....
0090 00 3c 01 00 00 36 28 8c d5 74 19 06 87 4d aa 3c  ..c.,6(.t..M.\
00a0 56 58 25 47 71 5e 00 00 00 00 00 00 00 01 00 00  VWSq.....
00b0 80 a0 00 00 00 0e 00 00 00 00 00 00 00 00 00 00  .....
00c0 00 00 00 00 00 00 00 00 00 00 00 00 00 08 00  .....
00d0 00 0a 01 00 01 7c 00 01 00 00 27 10  .....
    
```

23

Outline

- PROFlenergy
 - Energy savings in manufacturing industries
 - What is PROFlenergy?
 - **Energy saving potential (PI – Daimler)**
- Large test set-up - Measurements
- Calculation tool – Some results
- Q & A



24

Measurement example by PI Germany



- Measurements on typical production cells
- **Goal:** quantify the benefits that could result from using PROFIenergy.

Measurement example by PI Germany

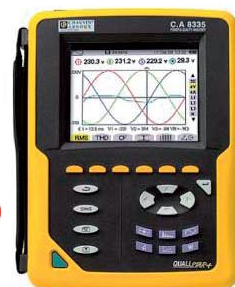
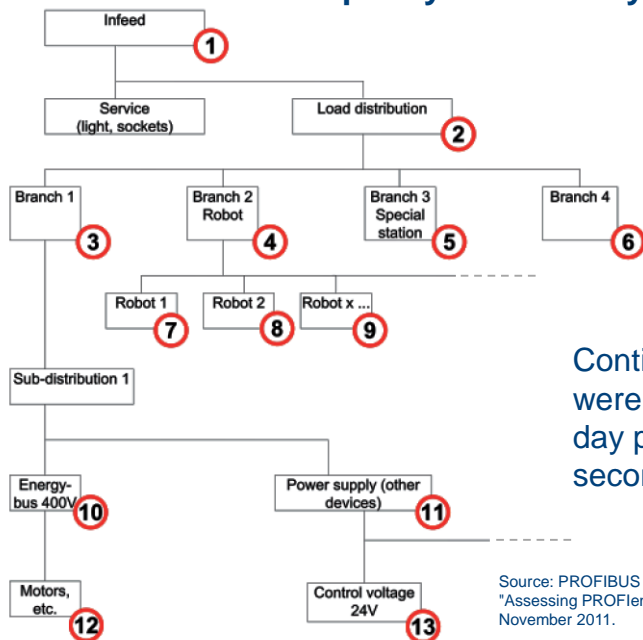

Continuous recordings were taken over a seven day period, at one second intervals.

Source: PROFIBUS Nutzerorganisation, "Assessing PROFIenergy's Potential," November 2011.

Measurement example by PI Germany

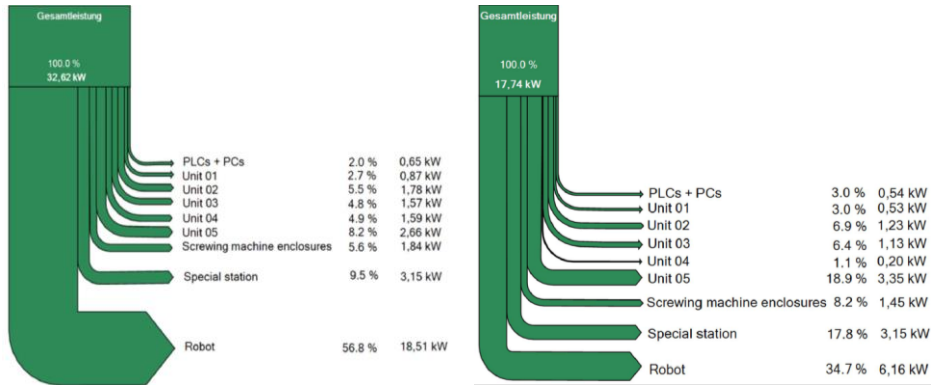

E.g. Robot: 18.51 kW during production and still uses 35% of that power (6.16 kW) during standstill

Source: F. Klasen, "PROFenergy Study,"

HEIn4.0

Co-funded by the Erasmus+ Programme of the European Union

KU LEUVEN

TECHNOLOGIECAMPUS GENT

27

Measurement example by PI Germany

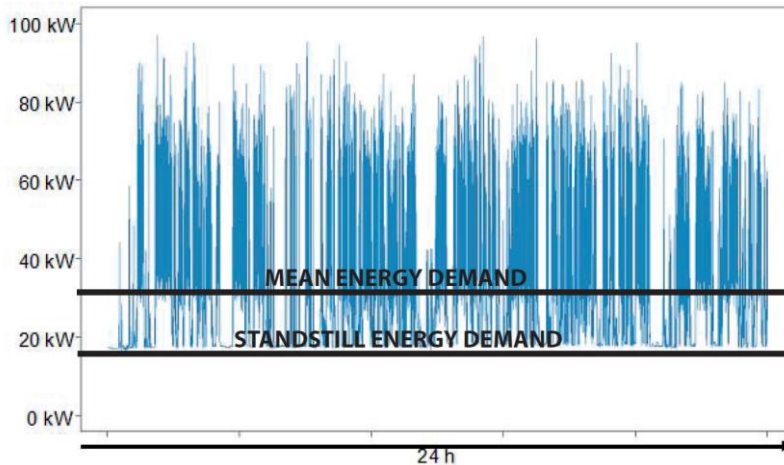

Base load during non-productive periods can be at least 50% of the total energy consumed.

Source: PROFIBUS Nutzerorganisation, "Assessing PROFenergy's Potential," November 2011.

HEIn4.0

Co-funded by the Erasmus+ Programme of the European Union

KU LEUVEN

TECHNOLOGIECAMPUS GENT

28

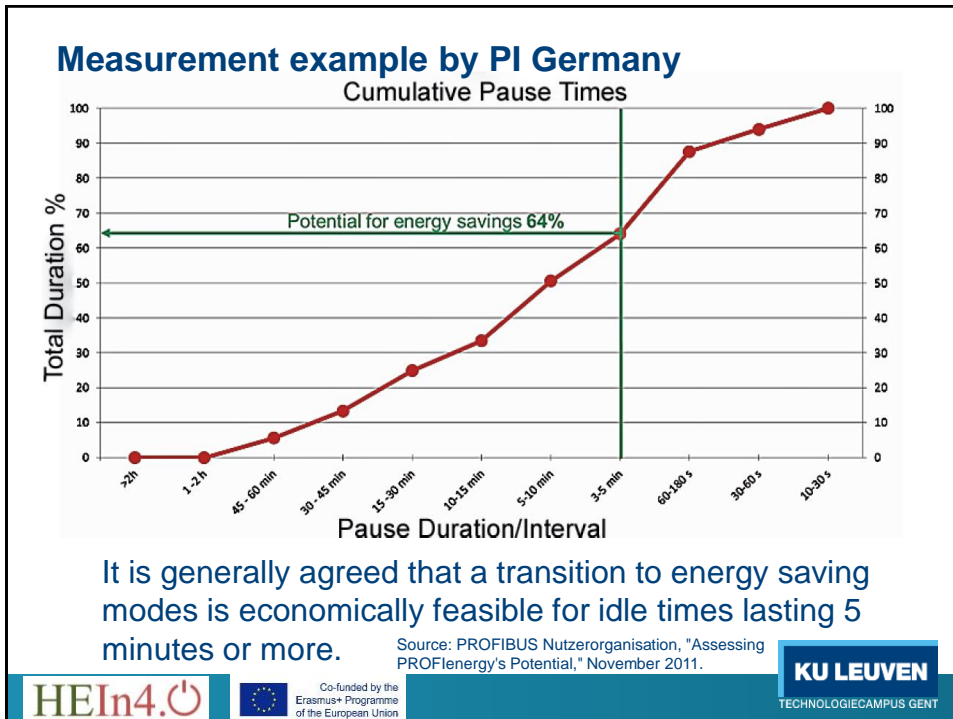

29

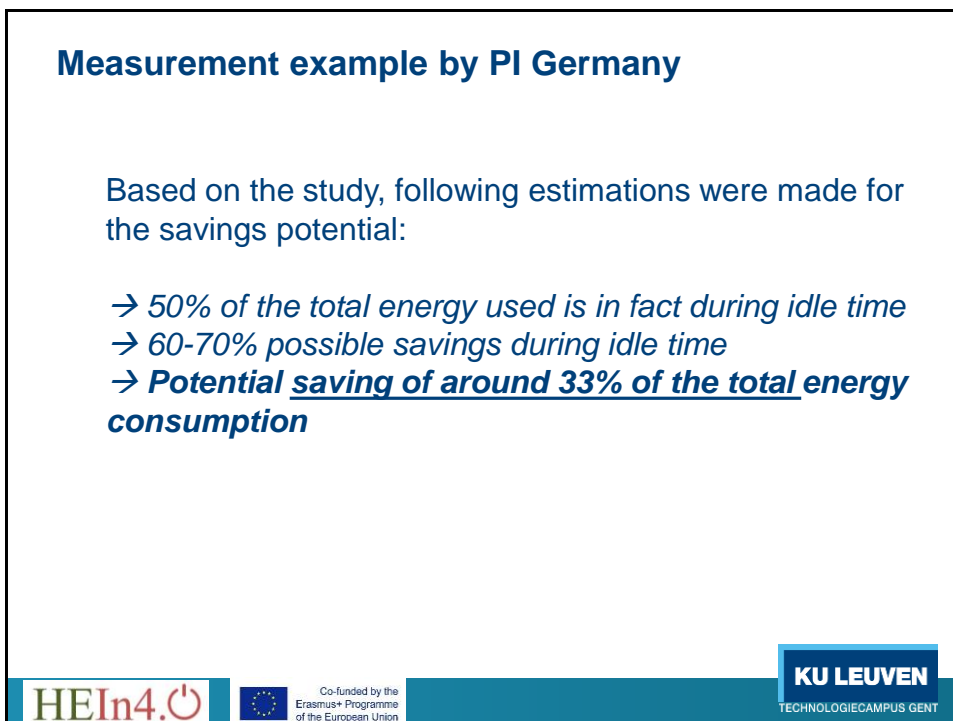

30

Measurement example by PI Germany

2-shift operation,

Time period: 5 work days + 2 weekend days

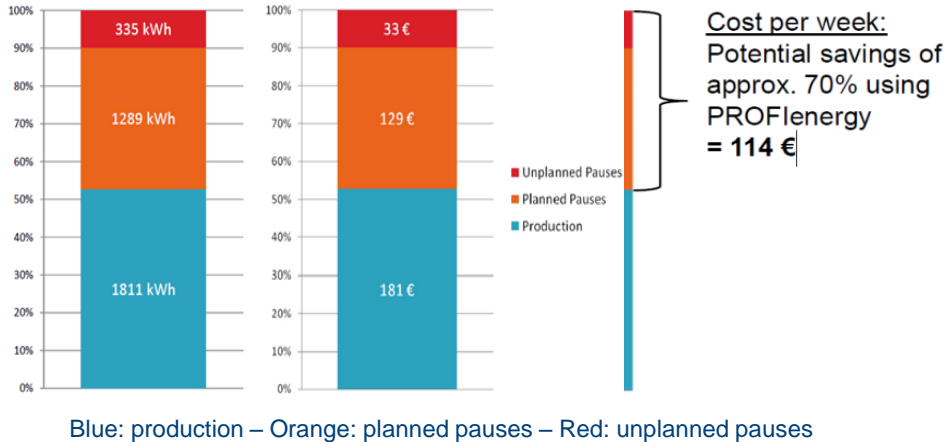

Source: F. Klasen, "PROFIenergy Study,"



31

Measurement example by PI Germany

2-shift operation,

Time period: 5 work days + 2 weekend days

CO₂ fuel mix factor is estimated at 0.59 kg/kWh. (1) estimates for Germany 0,546 kg/kWh.

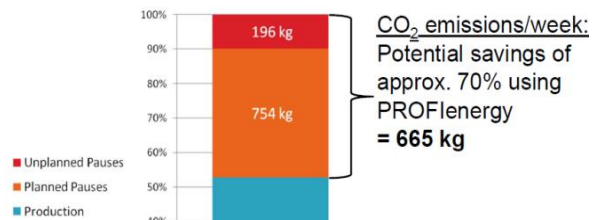

Source: F. Klasen, "PROFIenergy Study,"

Σ Energy [kWh]	Energy savings potential [kWh]	Σ Energy cost [€]	Savings potential Energy cost[€]	Σ CO-Emission [kg]	Savings potential CO-Emission[kg]	Savings potential in relation to total amount of energy[%]
172 750	57 000	17 250	5 700	100 450	33 250	33

(1) Siemens, "Application Guideline for Implementing Switch-off Concepts with PROFIenergy"



32

PROFlenergy

- Energy savings in manufacturing industries
- What is PROFlenergy?
- How do PROFlenergy commands look like in the network?
- **Measurements and analysis**
 - Measurements at Daimler
 - **Work within the INCASE project**
 - 1) Larger lab demonstrators
 - 2) Calculation tool, to extend measurements to larger use cases (cf. Volvo Cars Gent)



Outline

- PROFlenergy
 - Energy savings in manufacturing industries
 - What is PROFlenergy?
 - Energy saving potential (PI – Daimler)
- **Large test set-up - Measurements**
- Calculation tool – Some results
- Q & A



Larger lab demonstrators

PROfEnergy larger set-up in KU Leuven – campus Gent

- IO-Link Laser distance sensor
- Energy logger SENTRONs PAC4200
- IO-Link Color sensor
- Electrical drive inside Block diagram with connections
- Ventilator+ motor
- IO-Device et200sp
- Touchscreen for HMI TP1500 comfort panel
- Balluff interface IO-Link to PROFINET

Co-funded by the Erasmus+ Programme of the European Union

35

Larger lab demonstrators

PROfEnergy larger set-up in KU Leuven – campus Gent

- Energy logger (PN: sentron-pac4200-41, sentron-pac4200-42, sentron-pac4200-43)
- Measurement point Energy logger
- Measurement point Main supply
- Measurement point Line filter
- Measurement point Drive
- Ventilator+ motor
- Measurement point DC supply
- Measurement point CPU + control circuit
- Measurement point Motor
- Measurement point braking resistor - Current
- Measurement point DC Link

Co-funded by the Erasmus+ Programme of the European Union

36

Larger lab demonstrators

PROFenergy larger set-up in KU Leuven – campus Gent

KU LEUVEN **INCASE: PROFenergy Demonstrator**

3 x 400 V + N

Height [mm]

Ball levitation

Time	Average height	Ball height	Setpoint
11:55:37 AM 2/26/2020			
11:56:10 AM 2/26/2020			
11:56:43 AM 2/26/2020			
11:57:16 AM 2/26/2020			

—Average height — Ball height — Setpoint

Demo state: Stop

Heat resistor PE:

Base heat resistor:

0 rpm

HEIn4.0 Co-funded by the Erasmus+ Programme of the European Union **KU LEUVEN** TECHNOLOGIECAMPUS GENT

37

Larger lab demonstrators

Electrical drive (PN: sinamics-g120-63)

SINAMICS G120 line filter

QUINT POWER DC supply

Current transformers 5:1

IO-Device (PN: et200sp178)

IO-Controller (PN: cpu1516-138)

DC measurement LEM boards

HEIn4.0 Co-funded by the Erasmus+ Programme of the European Union **KU LEUVEN** TECHNOLOGIECAMPUS GENT

38

Larger lab demonstrators

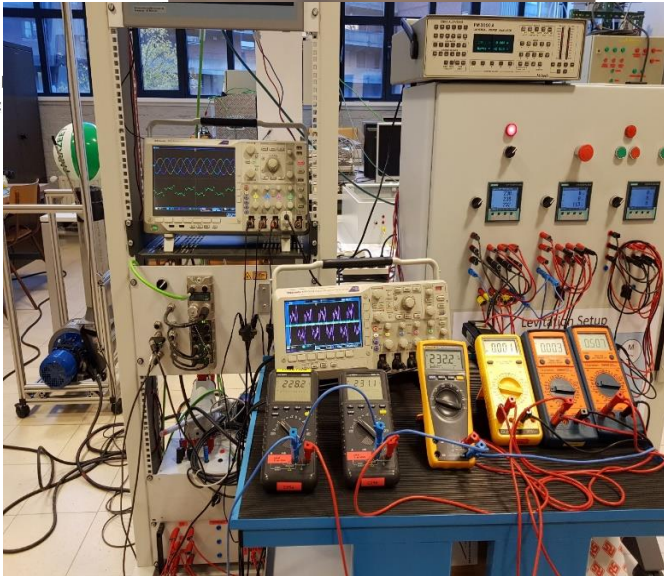
- 

(PN: ...)

Current transformers 5:1

IO-Device (PN: et200sp178)

IO-Controller (PN: cpu1516-138)

Measurement LEM boards

HEIn4.0

Co-funded by the Erasmus+ Programme of the European Union

KU LEUVEN
TECHNOLOGIECAMPUS GENT

39

Larger lab demonstrators

- Please refer to the movie.

HEIn4.0

Co-funded by the Erasmus+ Programme of the European Union

KU LEUVEN
TECHNOLOGIECAMPUS GENT

40

Larger lab demonstrators

PROFenergy larger set-up in KU Leuven – campus Gent

- Production cycle (left) + pause, ball kept at baseline height.

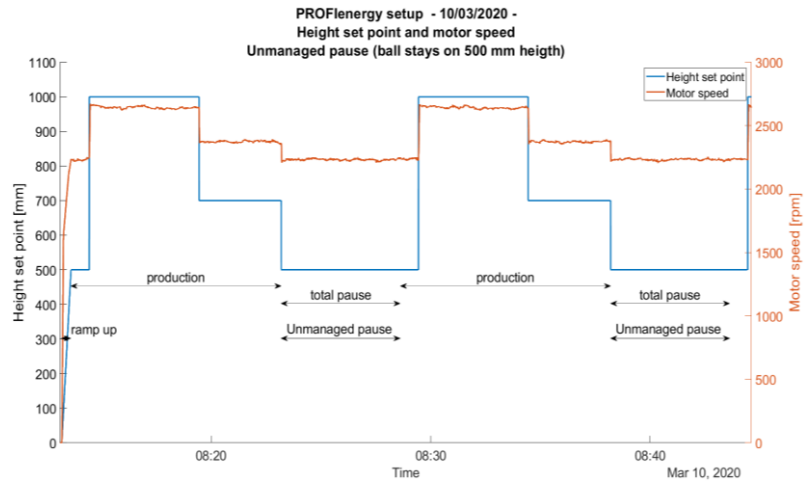

HEIn4.0

Co-funded by the
Erasmus+ Programme
of the European Union

KU LEUVEN

TECHNOLOGIECAMPUS GENT

41

Larger lab demonstrators

PROFenergy larger set-up in KU Leuven – campus Gent

- Production cycle (left) + pause, ball kept at baseline height.

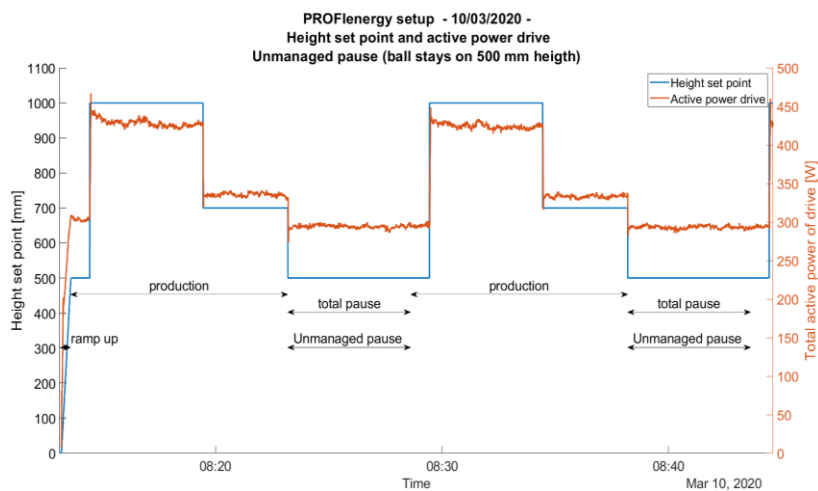

HEIn4.0

Co-funded by the
Erasmus+ Programme
of the European Union

KU LEUVEN

TECHNOLOGIECAMPUS GENT

42

Larger lab demonstrators

PROFenergy larger set-up in KU Leuven – campus Gent

- Production cycle (left) + pause, ball kept at baseline height.

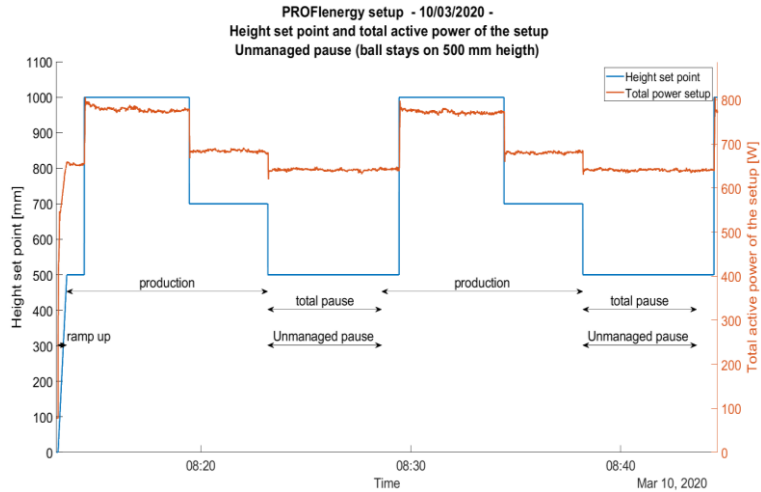

HEIn4.0

Co-funded by the
Erasmus+ Programme
of the European Union

KU LEUVEN
TECHNOLOGIECAMPUS GENT

43

Larger lab demonstrators

PROFenergy larger set-up in KU Leuven – campus Gent

- Production cycle (left) + pause, components in PE mode.

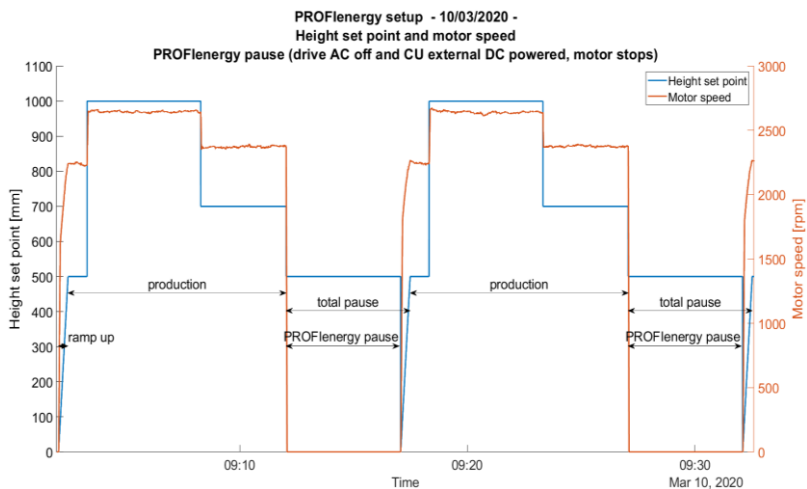

HEIn4.0

Co-funded by the
Erasmus+ Programme
of the European Union

KU LEUVEN
TECHNOLOGIECAMPUS GENT

44

Larger lab demonstrators

PROFenergy larger set-up in KU Leuven – campus Gent

- Production cycle (left) + pause, components in PE mode.

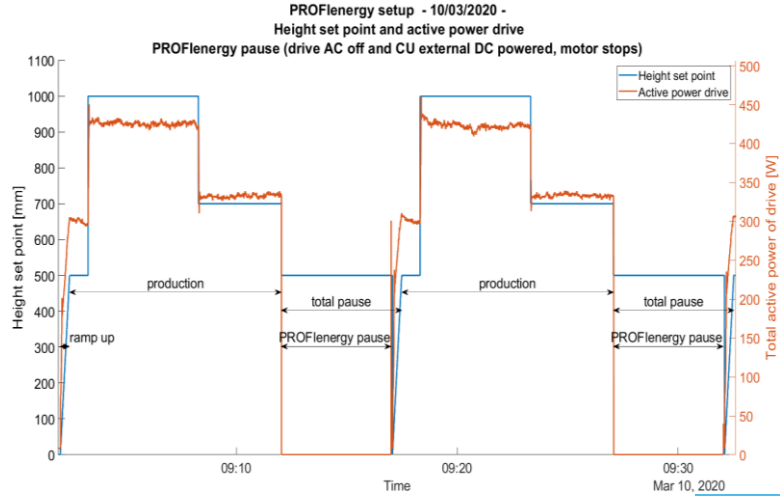

45

Larger lab demonstrators

PROFenergy larger set-up in KU Leuven – campus Gent

- Production cycle (left) + pause, components in PE mode.

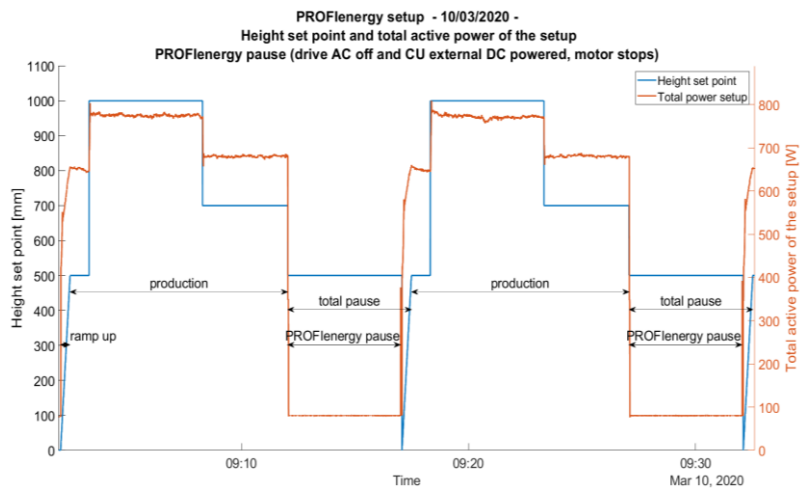

46

Outline

- PROFlenergy
 - Energy savings in manufacturing industries
 - What is PROFlenergy?
 - Energy saving potential (PI – Daimler)
- Large test set-up - Measurements
- **Calculation tool – Some results**
- Q & A



Calculation tool

PROFlenergy calculation tool

- Idea: measure for relevant components with high accuracy – combine with pauses – calculate for a larger industrial production line the energy saving potential.
- 3 use cases defined with observer partners Volvo Cars Gent & Siemens: a production cell, a conveyor belt and an overhead conveyor belt.

Calculation tool

PROfenergy calculation tool

- Example: TP1500 Comfort touch panel for HMI (Siemens)
- We assume 2 shifts/day, no work in the weekend; comparison “continuously on” versus “go to PE during breaks”.

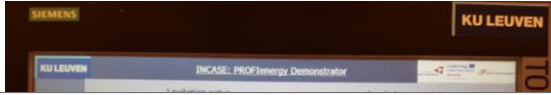

Device

Name:

Manufacturer:

Device Family:

Device Name:

Device Code:

Hardware Version:

Firmware Version:

PROfenergy Enabled:

Power Off Enabled:

Booting Time (s):

Booting Power (W):

Shutdown Time (s):

Shutdown Power (W):

ID	Info	Power (W)
0x00	PE_power_off	0
0xF0	operate	25,8
0xFF	PE_ready_to_operate	25,8
0x01	manufacturer specific	15,2

49

Calculation tool

PROfenergy calculation tool

- Example: TP1500 Comfort touch panel for HMI (Siemens)
- We assume 2 shifts/day, no work in the weekend; comparison “continuously on” versus “go to PE during breaks”.

Production Cell

Name:

Amount in plant:

Name	Manufacturer	Device Family	Device Name	Device Code	HW Version	FW Version	PE Compatible	PE Enabled
	Siemens	SIMATIC HMI	TP1500 Comfort	6AV2124-0QC02-0AX1	1.0.0	1.0.0	<input checked="" type="checkbox"/>	<input checked="" type="checkbox"/>

Manufacturer	Device Family	Device Name	Device Code	HW Version	FW Version
Siemens	SIMATIC S7-1500P	CPU 1516P-3 PN/DP	6ES7316-3PN01-0AB0	1.0.0	1.0.0
Siemens	SINAMICS G120	CU220S-2 PN Vector	6ES7348-0BA22-1FA0	1.0.0	1.0.0
Balluff	BNI PNT-502-105-Z015	BN0004U		1.0.0	1.0.0
Siemens	SIMATIC ET 200SP	IM 155-6 PN HF	6ES7195-6AU00-0CH0	1.0.0	1.0.0
Siemens	SIMATIC HMI	TP1500 Comfort	6AV2124-0QC02-0AX0	1.0.0	1.0.0
Siemens	SIMATIC HMI	TP1500 Comfort	6AV2124-0QC02-0AX1	1.0.0	1.0.0
Siemens	SETRON	PAC4200	7KM4212-0B400-3AA0	1.0.0	1.0.0

PROfenergy Calculation Tool

File

Start Time	Duration	End Time	PE Pause	Monday	Tuesday	Wednesday	Thursday	Friday	Saturday	Sunday
00:00	07:00	07:00	<input checked="" type="checkbox"/>	<input checked="" type="checkbox"/>	<input checked="" type="checkbox"/>	<input checked="" type="checkbox"/>	<input checked="" type="checkbox"/>	<input checked="" type="checkbox"/>	<input type="checkbox"/>	<input type="checkbox"/>
23:00	01:00	00:00	<input checked="" type="checkbox"/>	<input checked="" type="checkbox"/>	<input checked="" type="checkbox"/>	<input checked="" type="checkbox"/>	<input checked="" type="checkbox"/>	<input checked="" type="checkbox"/>	<input type="checkbox"/>	<input type="checkbox"/>
00:00	12:00	12:00	<input checked="" type="checkbox"/>	<input type="checkbox"/>	<input type="checkbox"/>	<input type="checkbox"/>	<input type="checkbox"/>	<input type="checkbox"/>	<input checked="" type="checkbox"/>	<input checked="" type="checkbox"/>
12:00	12:00	00:00	<input checked="" type="checkbox"/>	<input type="checkbox"/>	<input type="checkbox"/>	<input type="checkbox"/>	<input type="checkbox"/>	<input type="checkbox"/>	<input checked="" type="checkbox"/>	<input checked="" type="checkbox"/>

Interreg **2 Seas Mers Zeeën**

50

Calculation tool

PROFenergy calculation tool

- Example: TP1500 Comfort touch panel for HMI (Siemens)

The screenshot shows the PROFenergy Calculation Tool interface. The main window is titled "PROFenergy Calculation Tool" and contains the following elements:

- Energy prices per kWh:**
 - Week:** Day (€): 0,0673; Night (€): 0,0486; Day start: 07:00; Night start: 22:00
 - Weekend:** Day (€): 0,0486; Night (€): 0,0486; Day start: 07:00; Night start: 22:00
- Ignore pauses:** Ignore pauses shorter than or equal to 5 minutes
- Calculate:** A button to perform the calculation.
- Results:**

Weekly		Yearly	
Normal	PROFenergy	Normal	PROFenergy
4,33 kWh	3,40 kWh	226,01 kWh	177,37 kWh
€ 0,25	€ 0,20	€ 12,87	€ 10,51
Savings		Savings	
0,93 kWh	21,52 %	48,64 kWh	
€ 0,05	18,37 %	€ 2,36	

The interface also features a sidebar with navigation options (Library, Production Cells, Timetable, Calculation) and various logos including Interreg 2 Seas, INCASE, and KU LEUVEN.

51

This slide is mostly empty, showing a large white rectangular area. At the bottom, there is a footer containing the following logos and text:

- HEIn4.0** logo
- Co-funded by the Erasmus+ Programme of the European Union
- KU LEUVEN** logo
- TECHNOLOGIECAMPUS GENT

52

Calculation tool

PROFenergy calculation tool

- Example: TP1500 Comfort touch panel for HMI (Siemens)
- In fact, the touch panels are almost never used => turn around completely: always off, unless touched (we estimate 1 hour/week of usage). It is now adapted in the new Volvo Cars standard worldwide!

The screenshot shows the PROFenergy Calculation Tool interface. On the left, there are buttons for 'Library', 'Production Cells', 'Timetable', and 'Calculation'. The 'Timetable' button is highlighted. The main area displays a timetable with columns for days of the week and rows for time slots. The timetable is as follows:

Start Time	Duration	End Time	PE Pause	Monday	Tuesday	Wednesday	Thursday	Friday	Saturday	Sunday
00:00	12:00	12:00	<input checked="" type="checkbox"/>	<input checked="" type="checkbox"/>	<input checked="" type="checkbox"/>	<input checked="" type="checkbox"/>	<input checked="" type="checkbox"/>	<input type="checkbox"/>	<input checked="" type="checkbox"/>	<input checked="" type="checkbox"/>
12:00	12:00	00:00	<input checked="" type="checkbox"/>	<input checked="" type="checkbox"/>	<input checked="" type="checkbox"/>	<input checked="" type="checkbox"/>	<input checked="" type="checkbox"/>	<input type="checkbox"/>	<input checked="" type="checkbox"/>	<input checked="" type="checkbox"/>
00:00	12:00	12:00	<input checked="" type="checkbox"/>	<input type="checkbox"/>	<input type="checkbox"/>	<input type="checkbox"/>	<input type="checkbox"/>	<input checked="" type="checkbox"/>	<input type="checkbox"/>	<input type="checkbox"/>
13:00	11:00	00:00	<input checked="" type="checkbox"/>	<input type="checkbox"/>	<input type="checkbox"/>	<input type="checkbox"/>	<input type="checkbox"/>	<input checked="" type="checkbox"/>	<input type="checkbox"/>	<input type="checkbox"/>

The background image shows a Siemens HMI touch panel displaying a schematic diagram of a power system with components like 'PROFENERGY 1' and 'PROFENERGY 2'.

53

Calculation tool

PROFenergy calculation tool

- Ex
- In
- co
- US

The screenshot shows the PROFenergy Calculation Tool interface with the 'Energy prices per kWh' section active. The settings are as follows:

Week		Weekend	
Day (€):	0,0673	Day (€):	0,0486
Night (€):	0,0486	Night (€):	0,0486
Day start:	07:00	Day start:	07:00
Night start:	22:00	Night start:	22:00

There is a checkbox for 'Ignore pauses shorter than or equal to 5 minutes' which is currently unchecked. A 'Calculate' button is visible below the settings.

The calculation results are shown in the following table:

Weekly		Yearly	
Normal	PROFenergy	Normal	PROFenergy
4,33 kWh	2,56 kWh	226,01 kWh	133,70 kWh
€ 0,25	€ 0,15	€ 12,87	€ 7,62
Savings		Savings	
1,77 kWh	40,84 %	92,30 kWh	
€ 0,10	40,80 %	€ 5,25	

The interface also features logos for Interreg, 2 Seas Mers Zeeën, and INCASE, along with the European Regional Development Fund logo.

54

Calculation tool

PROFenergy calculation tool

- Example: TP1500 Comfort touch panel for HMI (Siemens)

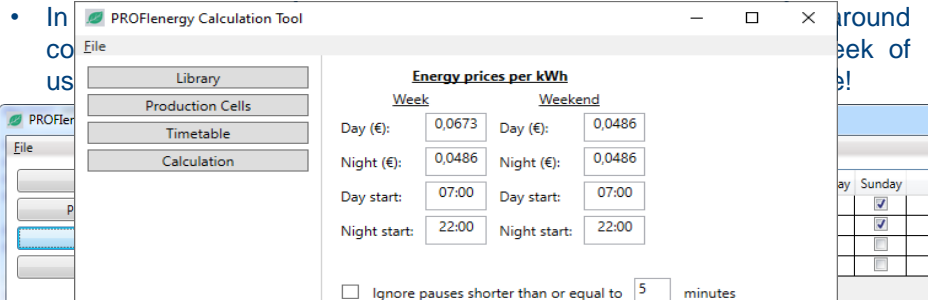
- In 

PROFenergy calculation tool

- There are about 150 of those HMI panels in VCG => about 13.800 kWh/year
- With the Belgian typical fuel mix in energy production (1): about 3600 kg of CO₂ per year. With the EU average: 6000 kg CO₂.

(1) "Electricity carbon intensity in European Member States: Impacts on GHG emissions of electric vehicles", A. Moro, L. Lonza, in "Transportation research", 2018, pag. 5-14
(at MV: 0.263 kg/kWh in BE, 0.432 kg/kWh EU28, 0,101 kg/kWh in France)

55



HEIn4.0  Co-funded by the Erasmus+ Programme of the European Union  **KU LEUVEN**
TECHNOLOGIECAMPUS GENT

56

Calculation tool

PROFenergy calculation tool

- Example: ball levitation
- HMI panel, G120 drive and ET200 SP PN IO-Device can go in PE mode.



HEIn4.0

Erasmus+ Programme of the European Union

KU LEUVEN

TECHNOLOGIECAMPUS GENT

57

Calculation tool

Production Cell

Name: Levitation setup

Amount in plant: 1

Devices in the production cell:

Name	Manufacturer	Device Family	Device Name	Device Code	HW Version	FW Version	PE Compatible	PE Enabled
	Siemens	SIMATIC S7-1500F	CPU 1516F-3 PN/DP	6ES7516-3FN01-0AB0	1.0.0	1.0.0	<input type="checkbox"/>	<input type="checkbox"/>
	Siemens	SINAMICS G120	CU250S-2 PN Vector	6SL3246-0BA22-1FA0	1.0.0	1.0.0	<input checked="" type="checkbox"/>	<input checked="" type="checkbox"/>
	Balluff		BNI PNT-502-105-Z015	BNI004U	1.0.0	1.0.0	<input type="checkbox"/>	<input type="checkbox"/>
PE	Siemens	SIMATIC ET 200SP	IM 155-6 PN HF	6ES7155-6AU00-0CNO	1.0.0	1.0.0	<input checked="" type="checkbox"/>	<input checked="" type="checkbox"/>
Measurement	Siemens	SIMATIC ET 200SP	IM 155-6 PN HF	6ES7155-6AU00-0CNO	1.0.0	1.0.0	<input checked="" type="checkbox"/>	<input type="checkbox"/>
	Siemens	SIMATIC HMI	TP1500 Comfort	6AV2124-0QC02-0AX1	1.0.0	1.0.0	<input checked="" type="checkbox"/>	<input checked="" type="checkbox"/>
	Siemens	SENTRON	PAC4200	7KM4212-0BA00-3AA0	1.0.0	1.0.0	<input type="checkbox"/>	<input type="checkbox"/>
	Siemens	SENTRON	PAC4200	7KM4212-0BA00-3AA0	1.0.0	1.0.0	<input type="checkbox"/>	<input type="checkbox"/>
	Siemens	SENTRON	PAC4200	7KM4212-0BA00-3AA0	1.0.0	1.0.0	<input type="checkbox"/>	<input type="checkbox"/>

PROFenergy Calculation Tool

File

Library
Production Cells
Timetable
Calculation

Start Time	Duration	End Time	PE Pause	Power Off	Monday	Tuesday	Wednesday	Thursday	Friday	Saturday	Sunday
00:00	07:00	07:00	<input checked="" type="checkbox"/>	<input type="checkbox"/>	<input checked="" type="checkbox"/>	<input checked="" type="checkbox"/>	<input checked="" type="checkbox"/>	<input checked="" type="checkbox"/>	<input checked="" type="checkbox"/>	<input type="checkbox"/>	<input type="checkbox"/>
23:00	01:00	00:00	<input checked="" type="checkbox"/>	<input type="checkbox"/>	<input checked="" type="checkbox"/>	<input checked="" type="checkbox"/>	<input checked="" type="checkbox"/>	<input checked="" type="checkbox"/>	<input checked="" type="checkbox"/>	<input type="checkbox"/>	<input type="checkbox"/>
00:00	12:00	12:00	<input checked="" type="checkbox"/>	<input type="checkbox"/>	<input type="checkbox"/>	<input type="checkbox"/>	<input type="checkbox"/>	<input type="checkbox"/>	<input type="checkbox"/>	<input checked="" type="checkbox"/>	<input checked="" type="checkbox"/>
12:00	12:00	00:00	<input checked="" type="checkbox"/>	<input type="checkbox"/>	<input type="checkbox"/>	<input type="checkbox"/>	<input type="checkbox"/>	<input type="checkbox"/>	<input type="checkbox"/>	<input checked="" type="checkbox"/>	<input checked="" type="checkbox"/>
09:00	00:05	09:05	<input checked="" type="checkbox"/>	<input type="checkbox"/>	<input checked="" type="checkbox"/>	<input checked="" type="checkbox"/>	<input checked="" type="checkbox"/>	<input checked="" type="checkbox"/>	<input checked="" type="checkbox"/>	<input type="checkbox"/>	<input type="checkbox"/>
11:05	00:25	11:30	<input checked="" type="checkbox"/>	<input type="checkbox"/>	<input checked="" type="checkbox"/>	<input checked="" type="checkbox"/>	<input checked="" type="checkbox"/>	<input checked="" type="checkbox"/>	<input checked="" type="checkbox"/>	<input type="checkbox"/>	<input type="checkbox"/>
13:30	00:05	13:35	<input checked="" type="checkbox"/>	<input type="checkbox"/>	<input checked="" type="checkbox"/>	<input checked="" type="checkbox"/>	<input checked="" type="checkbox"/>	<input checked="" type="checkbox"/>	<input checked="" type="checkbox"/>	<input type="checkbox"/>	<input type="checkbox"/>
14:55	00:10	15:05	<input checked="" type="checkbox"/>	<input type="checkbox"/>	<input checked="" type="checkbox"/>	<input checked="" type="checkbox"/>	<input checked="" type="checkbox"/>	<input checked="" type="checkbox"/>	<input checked="" type="checkbox"/>	<input type="checkbox"/>	<input type="checkbox"/>
17:05	00:05	17:10	<input checked="" type="checkbox"/>	<input type="checkbox"/>	<input checked="" type="checkbox"/>	<input checked="" type="checkbox"/>	<input checked="" type="checkbox"/>	<input checked="" type="checkbox"/>	<input checked="" type="checkbox"/>	<input type="checkbox"/>	<input type="checkbox"/>
19:10	00:25	19:35	<input checked="" type="checkbox"/>	<input type="checkbox"/>	<input checked="" type="checkbox"/>	<input checked="" type="checkbox"/>	<input checked="" type="checkbox"/>	<input checked="" type="checkbox"/>	<input checked="" type="checkbox"/>	<input type="checkbox"/>	<input type="checkbox"/>
21:35	00:05	21:40	<input checked="" type="checkbox"/>	<input type="checkbox"/>	<input checked="" type="checkbox"/>	<input checked="" type="checkbox"/>	<input checked="" type="checkbox"/>	<input checked="" type="checkbox"/>	<input checked="" type="checkbox"/>	<input type="checkbox"/>	<input type="checkbox"/>

Add pause
Manage pause
Copy pause
Delete pause

Interreg
2 Seas Mers Zeeën
INCASE
European Regional Development Fund

58

Calculation tool

PROFIenergy calculation tool

- Exam
- HMI

PROFIenergy Calculation Tool

File

Library

Production Cells

Timetable

Calculation

Energy prices per kWh

Week		Weekend	
Day (€):	0,0673	Day (€):	0,0486
Night (€):	0,0486	Night (€):	0,0486
Day start:	07:00	Day start:	07:00
Night start:	22:00	Night start:	22:00

Ignore pauses shorter than or equal to 5 minutes

Calculate

Weekly		Yearly	
Normal	PROFIenergy	Normal	PROFIenergy
121,84 kWh	100,76 kWh	6352,87 kWh	5254,04 kWh
€ 7,05	€ 6,00	€ 367,83	€ 313,04
Savings		Savings	
21,07 kWh	17,30 %	1098,83 kWh	€ 54,80
€ 1,05	14,90 %		

Interreg 2 Seas Mers Zeeën INCASE European Regional Development Fund

PROFIenergy calculation tool – ball levitation

- 3 shifts: about 10 %.
- Showing energy savings potential.

59

HEIn4.0

Co-funded by the Erasmus+ Programme of the European Union

KU LEUVEN TECHNOLOGIECAMPUS GENT

60

Finally

PROFenergy calculation tool

- Ongoing work at Volvo Cars Gent, in cooperation with Siemens and ABB (for the robots).
- Determining additional typical numbers for energy saving potential at Volvo Cars Gent: consumption of ABB robots, larger drives, etc.
- Depending on the outcome, co-develop software and applications of “real-life” automation program routines and standards => large demonstrator

Outline

- PROFenergy
 - Energy savings in manufacturing industries
 - What is PROFenergy?
 - Energy saving potential (PI – Daimler)
- Large test set-up - Measurements
- Calculation tool – Some results
- **Q & A - Movie**

